

SPDT RF SWITCH

50Ω DC-3000 MHz

Absorptive RF Switch with internal driver.
Single Supply Voltage , +3V

Product Features

- Very Low Insertion loss over entire frequency range
- Super High Isolation over entire frequency range
- High Input IP3, +55 dBm typ.
- Single positive supply voltage, +3V
- Very low DC current consumption, 8μA
- Immune to latch up
- Unique design-simultaneous switch off of RF1&RF2

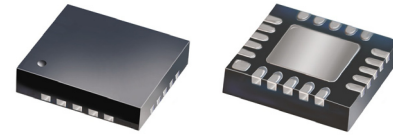

HSWA2-30DR+

CASE STYLE: DG983-1
PRICE: \$2.95 ea. QTY. (10-49)

Typical Applications

- Base Station Infrastructure
- Portable Wireless
- CATV & DBS
- MMDS & Wireless LAN
- Band switch
- Diplexer switches
- Bypass switches

+ RoHS compliant in accordance
with EU Directive (2002/95/EC)

The +Suffix has been added in order to identify RoHS Compliance. See our web site for RoHS Compliance methodologies and qualifications.

General Description

The HSWA2-30DR+ is a 50Ω high isolation SPDT RF switch designed for wireless applications, covering a broad frequency range from DC up to 3GHz with low insertion loss. The HSWA2-30DR+ operates on a single supply voltage +3V. See application note AN-80-006 for +5V supply voltage. This unit includes an internal CMOS control driver with two-pins control. The switch consumes very low supply current, 8 μA typ. The HSWA2-30DR+ switch is in a very small size and low profile package, 4x4mm and 0.9mm respectively.

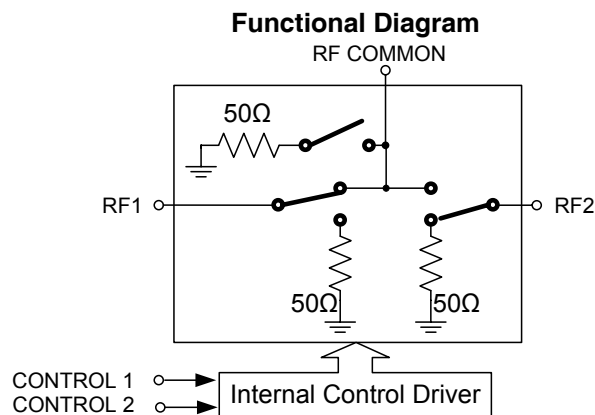

Mini-Circuits
ISO 9001 ISO 14001 AS 9100 CERTIFIED
The Design Engineers Search Engine Provides ACTUAL Data Instantly at minicircuits.com

For detailed performance specs
& shopping online see web site

P.O. Box 350166, Brooklyn, New York 11235-0003 (718) 934-4500 Fax (718) 332-4661

IF/RF MICROWAVE COMPONENTS

Notes: 1. Performance and quality attributes and conditions not expressly stated in this specification sheet are intended to be excluded and do not form a part of this specification sheet. 2. Electrical specifications and performance data contained herein are based on Mini-Circuit's applicable established test performance criteria and measurement instructions. 3. The parts covered by this specification sheet are subject to Mini-Circuits standard limited warranty and terms and conditions (collectively, "Standard Terms"); Purchasers of this part are entitled to the rights and benefits contained therein. For a full statement of the Standard Terms and the exclusive rights and remedies thereunder, please visit Mini-Circuits' website at www.minicircuits.com/MCLStore/terms.jsp.

Rev. H
M126943
HSWA2-30DR+
100411
Page 1 of 11

RF Electrical Specifications, DC-3000 MHz, $T_{AMB}=25^{\circ}C$, $V_{DD}=+3V$

Parameter	Condition	Min.	Typ.	Max.	Units
Operating Frequency		DC (note 4)		3000	MHz
Insertion Loss (note 1)	1 GHz		0.75	1.0	dB
	2 GHz		0.95	1.2	
	3 GHz		1.2	1.4	
Isolation between Common port and RF1/RF2 ports	1 GHz	55	64		dB
	2 GHz	46	50		
	3 GHz	40	44		
Isolation between RF1 and RF2 ports	1 GHz	57	63		dB
	2 GHz	54	60		
	3 GHz	40	48		
Return Loss @ Common port	1 GHz		20		dB
	2 GHz		17		
	3 GHz		14		
Return Loss @ RF1/RF2 ports	1 GHz		20		dB
	2 GHz		18		
	3 GHz		17		
Input IP2	5 MHz - 1000 MHz		+80		dBm
Input IP3 (note 2)	10 MHz - 1000MHz		+55		dBm
	1000MHz - 3000MHz		+52		
Input 1dB Compression (note 2,3)	1000 MHz	+29	+31		dBm

Notes:

1. I.LOSS values are de-embedded from test board Loss.
2. Device linearity degrades below 1 MHz.
3. Note absolute maximum ratings for input power.
4. Lowest Freq. determined by value of coupling capacitors at RF ports.

DC Electrical Specifications

Parameter	Min.	Typ.	Max.	Units
V_{DD} , Supply Voltage (note 5)	2.7	3	3.3	V
Supply Current ($V_{DD} = 3V$) (note 6)	—	8	20	μA
Control Voltage Low	0	—	$0.3 \times V_{DD}$	V
Control Voltage High	$0.7 \times V_{DD}$	—	V_{DD}	V

Note 5: See application note AN-80-006 for +5V supply voltage.

Note 6: At Control Frequency of 1 kHz. Increases to 21 μA at 10 kHz and 56 μA at 50 kHz typically.

Switching Specifications

Parameter	Min.	Typ.	Max.	Units
Switching Time, 50% CTRL to 90/10% RF	—	2.0	—	μSec
Video Feedthrough, 5 MHz - 1000 MHz (note 7)	—	—	15	mV _{P-P}

Note 7: Measured with a 1 nSec risetime, 0/3V pulse and 500 MHz bandwidth.

Absolute Maximum Ratings

Parameter	Ratings
Operating Temperature	-40°C to 85°C
Storage Temperature	-65°C to 150°C
V_{DD} , Supply Voltage	-0.3V Min., 4V Max.
Voltage control	-0.3V Min., $V_{DD} + 0.3V$ Max.
ESD, HBM (ANSI/ESD STM 5.1 - 2001)	250V to < 500V (CLASS 1A)
ESD, MM (ANSI/ESD STM 5.2 - 1999)	50V (CLASS M1)
RF input power: (note 8)	
When the common port is connected to the RF port (RF1 or RF2)	+33dBm
When the RF port (RF1 or RF2) is not connected to the common port	+24dBm
When the common port is not connected to either RF1 or RF2	+24dBm

Note 8: See Truth Table on page 3.

Permanent damage may occur if any of these limits are exceeded.



For detailed performance specs & shopping online see web site

P.O. Box 350166, Brooklyn, New York 11235-0003 (718) 934-4500 Fax (718) 332-4661 The Design Engineers Search Engine Provides ACTUAL Data Instantly at minicircuits.com

Notes: 1. Performance and quality attributes and conditions not expressly stated in this specification sheet are intended to be excluded and do not form a part of this specification sheet. 2. Electrical specifications and performance data contained herein are based on Mini-Circuit's applicable established test performance criteria and measurement instructions. 3. The parts covered by this specification sheet are subject to Mini-Circuits standard limited warranty and terms and conditions (collectively, "Standard Terms"); Purchasers of this part are entitled to the rights and benefits contained therein. For a full statement of the Standard Terms and the exclusive rights and remedies thereunder, please visit Mini-Circuits' website at www.minicircuits.com/MCLStore/terms.jsp.

The RF switch control bits select the desired switch-state, as shown in **Table 1**: Truth Table.

Table 1: Truth Table.

STATE	Control Input		RF Input / Output	
	Control 1	Control 2	RF1 to RF COMMON	RF2 to RF COMMON
1	Low	Low	OFF	OFF
2	Low	High	OFF	ON
3	High	Low	ON	OFF
4	High	High	N/A	N/A

General notes:

1. When either of the RF1 or RF2 ports is closed (**ON** state), the closed port is connected to the RF Common port.
2. When either of the RF1 or RF2 ports is open (**OFF** state), the open port is connected to an internal 50Ω termination.
3. When both RF1 and RF2 ports are open (**OFF** state), the all three RF ports are connected to an internal 50Ω termination.

EXAMPLE OF STATE 3

Functional Diagram

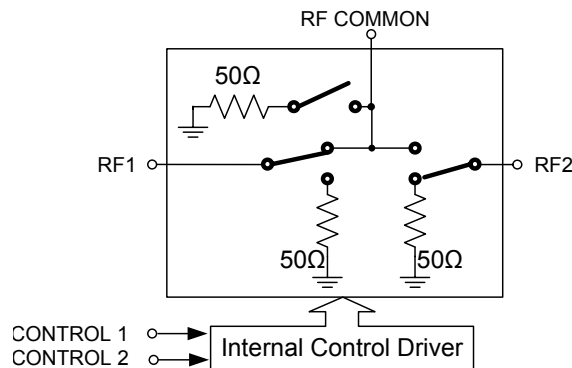

Pin Description

Function	Pin Number	Description
GND	1	RF Ground
GND	2	RF Ground
RF1	3	RF I/O (note 1)
GND	4	RF Ground
GND	5	RF Ground
GND	6	RF Ground
GND	7	RF Ground
RF COM	8	RF Common (note 1)
GND	9	RF Ground
GND	10	RF Ground
GND	11	RF Ground
GND	12	RF Ground
RF2	13	RF I/O (note 1)
GND	14	RF Ground
GND	15	RF Ground
Control 2	16	Control 2
Control 1	17	Control 1
GND	18	Supply Voltage Ground
GND	19	Digital Ground
VDD	20	Supply Voltage
GND	Paddle	RF Ground Pad (note 2)

Pin Configuration (Top View)

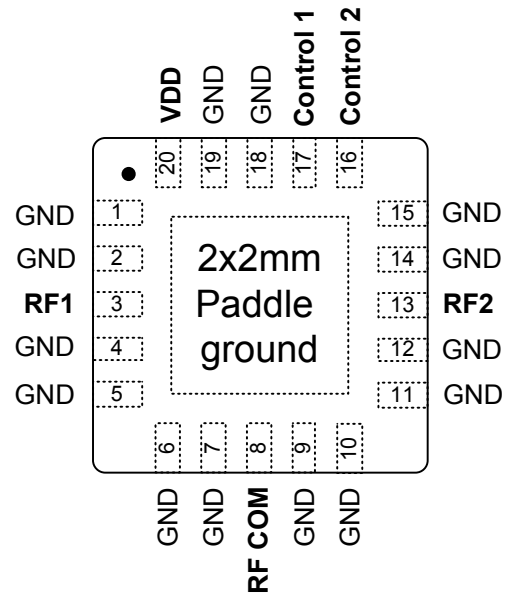

Notes:

- RF pins 3, 8 and 13 must be at 0 VDC. The RF pins do not require DC blocking capacitors for proper operation if the 0 VDC requirement is met.
- The exposed solder pad on the bottom of the package (See Pin Configuration) must be grounded for proper device operation

Typical Performance Curves over various states. For switch state see Truth Table 1 on page 3.

INSERTION LOSS Vs. FREQUENCY @ +25°C

INSERTION LOSS Vs. FREQUENCY

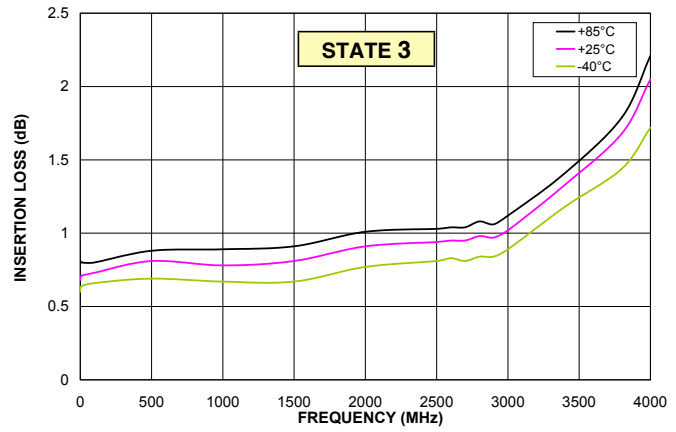
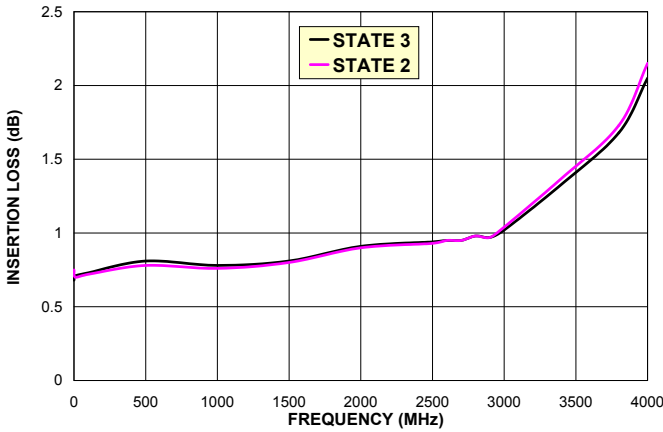

ISOLATION BETWEEN RF1/RF2 TO RF COM Vs. FREQUENCY

ISOLATION BETWEEN RF1/RF2 TO RF COM Vs. FREQUENCY

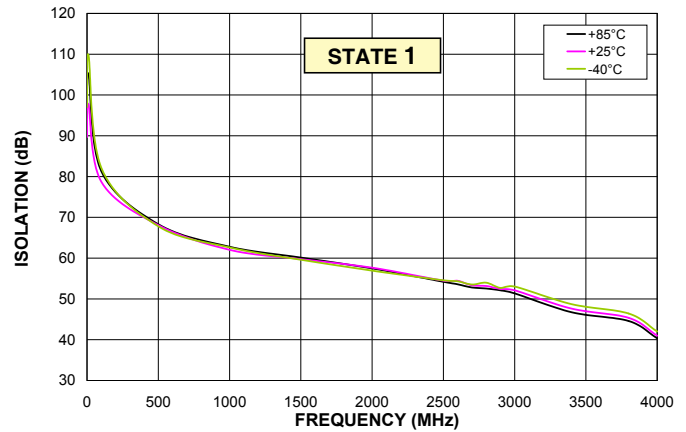
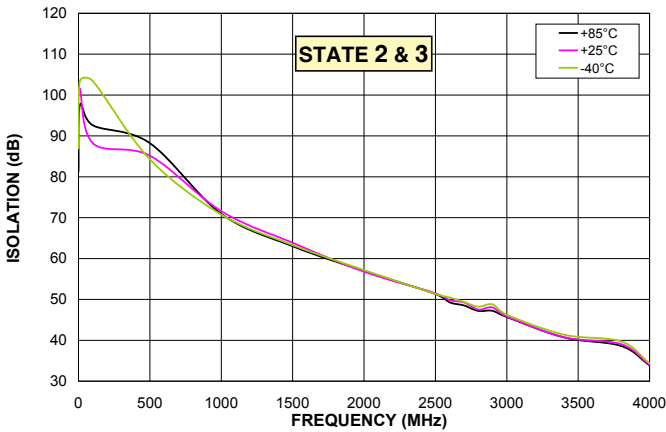

ISOLATION BETWEEN RF1 TO RF2 Vs. FREQUENCY

ISOLATION BETWEEN RF1 TO RF2 Vs. FREQUENCY

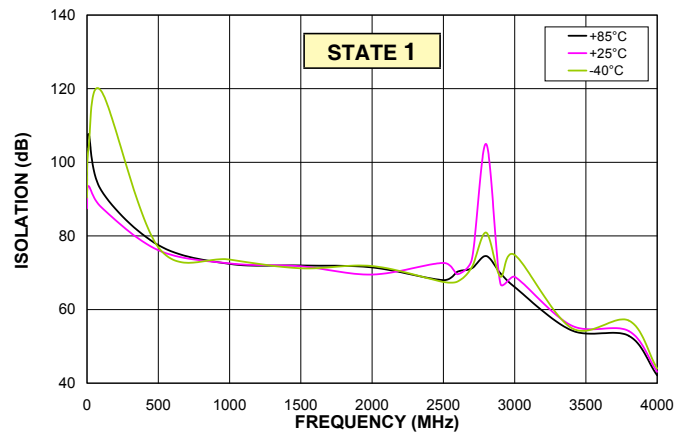
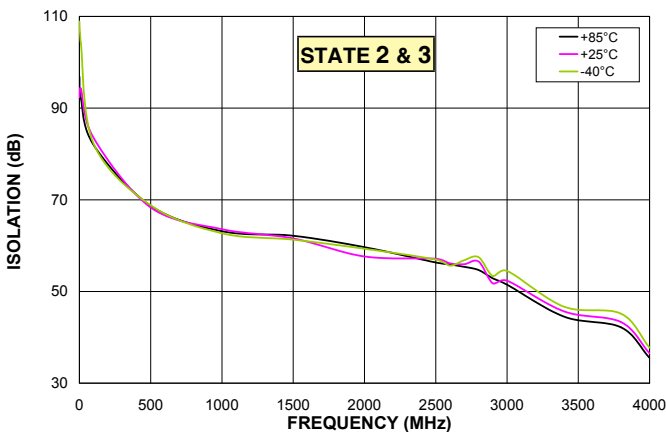

For detailed performance specs & shopping online see web site

P.O. Box 350166, Brooklyn, New York 11235-0003 (718) 934-4500 Fax (718) 332-4661 The Design Engineers Search Engine Provides ACTUAL Data Instantly at minicircuits.com

IF/RF MICROWAVE COMPONENTS

Notes: 1. Performance and quality attributes and conditions not expressly stated in this specification sheet are intended to be excluded and do not form a part of this specification sheet. 2. Electrical specifications and performance data contained herein are based on Mini-Circuit's applicable established test performance criteria and measurement instructions. 3. The parts covered by this specification sheet are subject to Mini-Circuits standard limited warranty and terms and conditions (collectively, "Standard Terms"); Purchasers of this part are entitled to the rights and benefits contained therein. For a full statement of the Standard Terms and the exclusive rights and remedies thereunder, please visit Mini-Circuits' website at www.minicircuits.com/MCLStore/terms.jsp.

SPDT RF SWITCH

HSWA2-30DR+

Typical Performance Curves over various states. For switch state see Truth Table 1 on page 3.

RF RETURN LOSS Vs. FREQUENCY @ +25°C

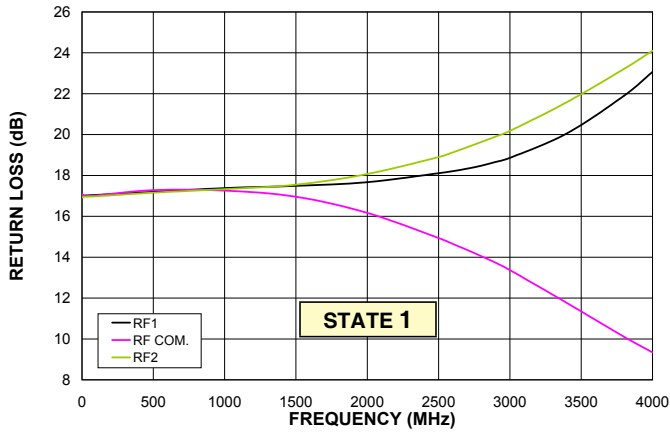

RF COM RETURN LOSS Vs. FREQUENCY @ +25°C

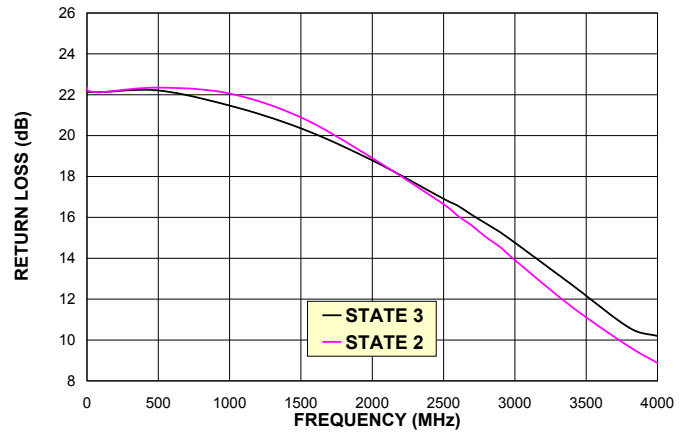

RF1 RETURN LOSS Vs. FREQUENCY

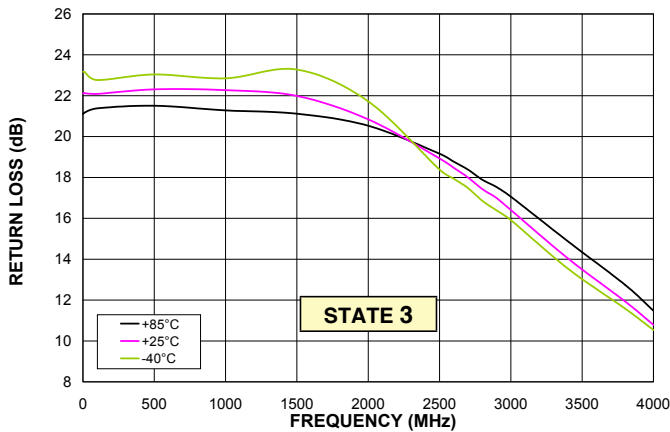

RF COM RETURN LOSS Vs. FREQUENCY

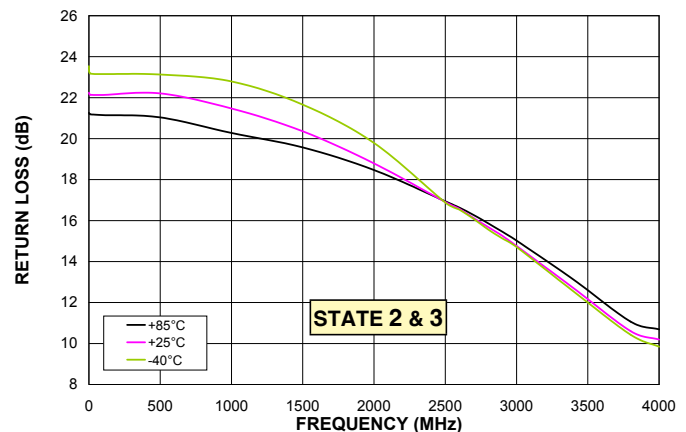

RF1 RETURN LOSS Vs. FREQUENCY

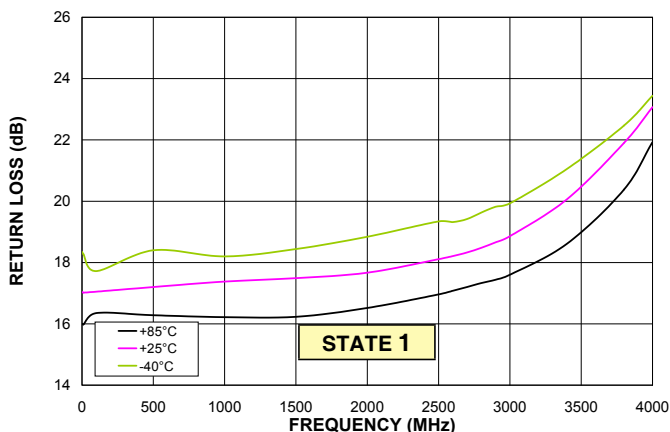

RF COM RETURN LOSS Vs. FREQUENCY

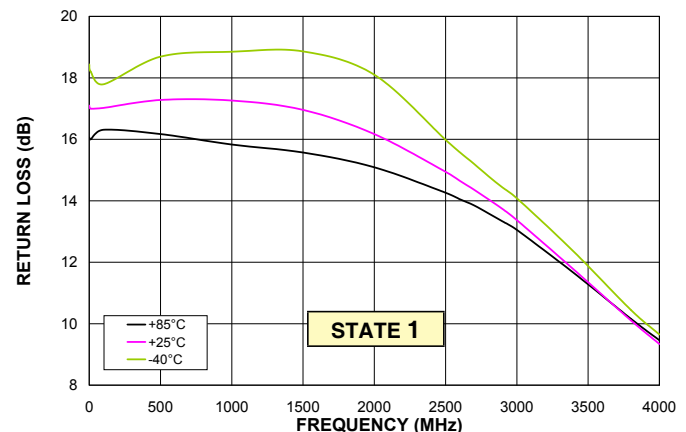

For detailed performance specs & shopping online see web site

P.O. Box 350166, Brooklyn, New York 11235-0003 (718) 934-4500 Fax (718) 332-4661 The Design Engineers Search Engine Provides ACTUAL Data Instantly at minicircuits.com

IF/RF MICROWAVE COMPONENTS

Notes: 1. Performance and quality attributes and conditions not expressly stated in this specification sheet are intended to be excluded and do not form a part of this specification sheet. 2. Electrical specifications and performance data contained herein are based on Mini-Circuit's applicable established test performance criteria and measurement instructions. 3. The parts covered by this specification sheet are subject to Mini-Circuits standard limited warranty and terms and conditions (collectively, "Standard Terms"); Purchasers of this part are entitled to the rights and benefits contained therein. For a full statement of the Standard Terms and the exclusive rights and remedies thereunder, please visit Mini-Circuits' website at www.minicircuits.com/MCLStore/terms.jsp.

SPDT RF SWITCH

HSWA2-30DR+

Typical Performance Curves over various states. For switch state see Truth Table 1 on page 3.

RF2 RETURN LOSS Vs. FREQUENCY

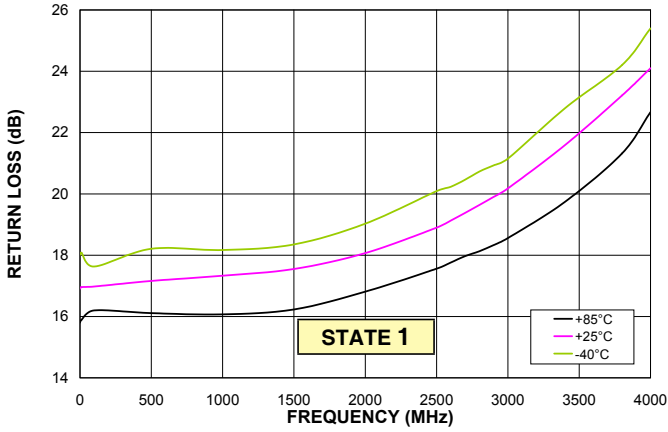

RF2 RETURN LOSS Vs. FREQUENCY

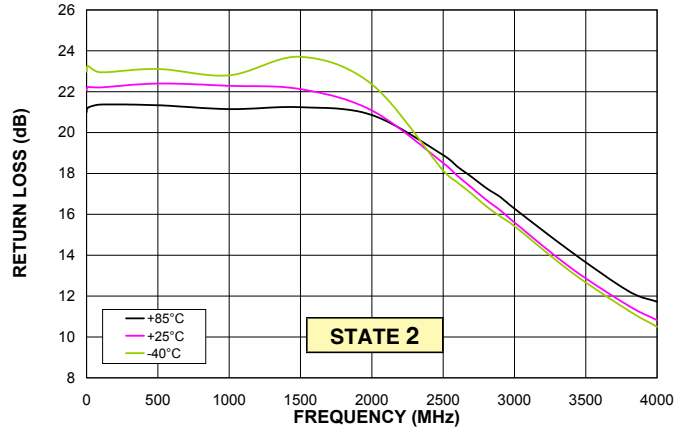

INPUT IP3 Vs. FREQUENCY

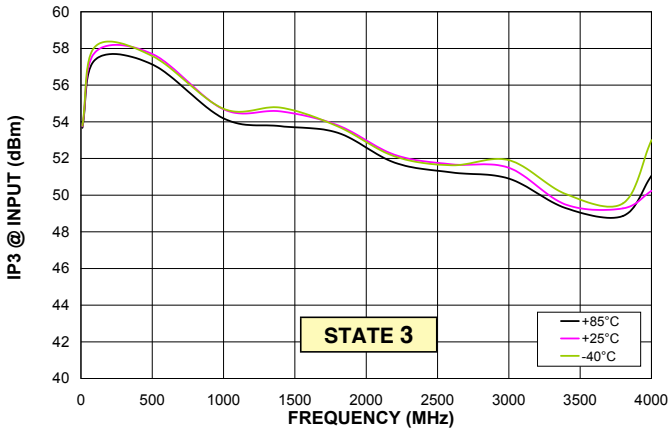

INPUT IP3 Vs. FREQUENCY

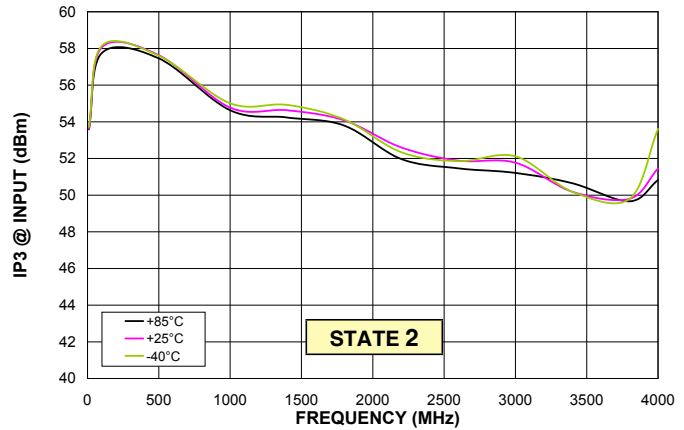

POWER IN @ 1dB COMPRESSION Vs. FREQUENCY

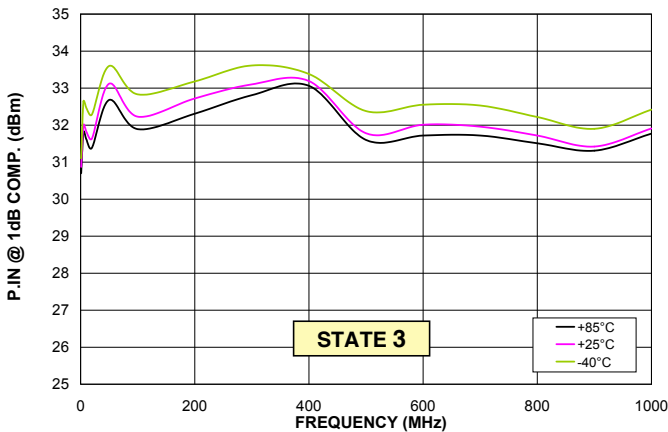

POWER IN @ 1dB COMPRESSION Vs. FREQUENCY

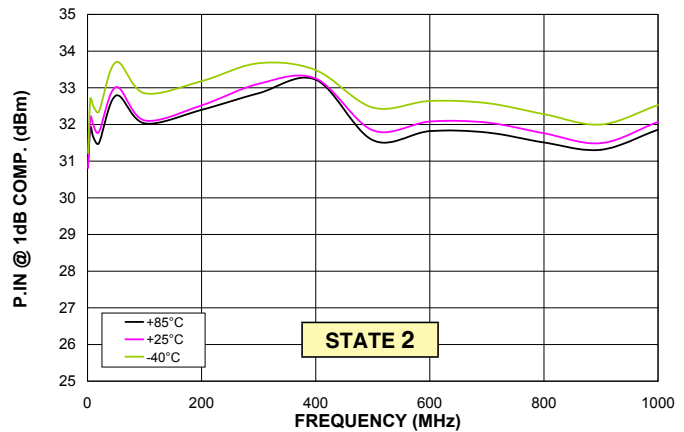

For detailed performance specs & shopping online see web site

P.O. Box 350166, Brooklyn, New York 11235-0003 (718) 934-4500 Fax (718) 332-4661 The Design Engineers Search Engine Provides ACTUAL Data Instantly at minicircuits.com

IF/RF MICROWAVE COMPONENTS

Notes: 1. Performance and quality attributes and conditions not expressly stated in this specification sheet are intended to be excluded and do not form a part of this specification sheet. 2. Electrical specifications and performance data contained herein are based on Mini-Circuit's applicable established test performance criteria and measurement instructions. 3. The parts covered by this specification sheet are subject to Mini-Circuits standard limited warranty and terms and conditions (collectively, "Standard Terms"); Purchasers of this part are entitled to the rights and benefits contained therein. For a full statement of the Standard Terms and the exclusive rights and remedies thereunder, please visit Mini-Circuits' website at www.minicircuits.com/MCLStore/terms.jsp.

Outline Drawing (DG983-1)

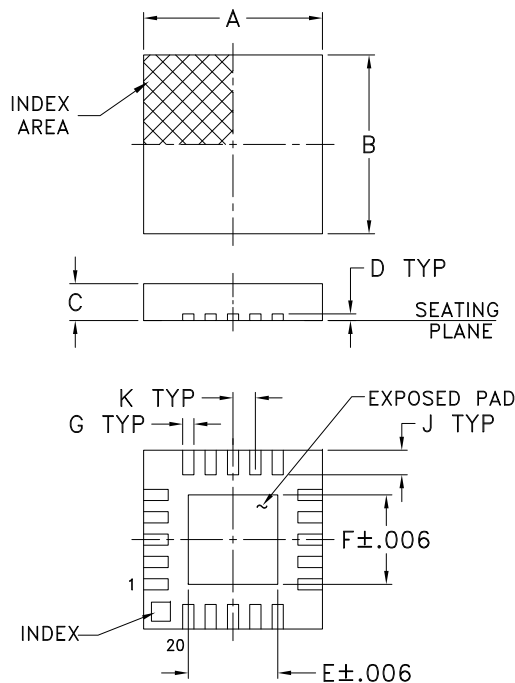

PCB Land Pattern

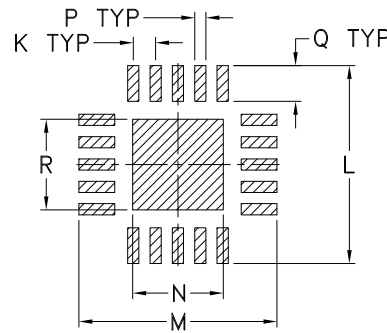

Suggested Layout,
Tolerance to be within $\pm .002$

Device Marking

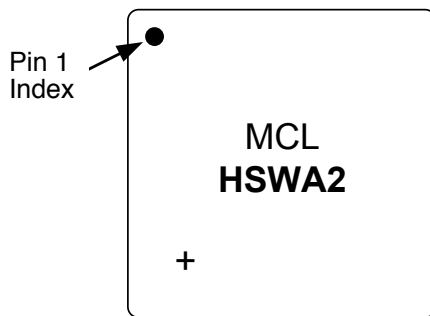

Outline Dimensions (inch/mm)

A	B	C	D	E	F	G	H	J	K	L	M	N	P	Q	R	WT. GRAMS
.157	.157	.035	.008	.081	.081	.010	—	.022	.020	.177	.177	.081	.010	.032	.081	.04
4.00	4.00	0.90	0.20	2.06	2.06	0.25	—	0.56	0.50	4.50	4.50	2.06	0.25	0.81	2.06	

Suggested Layout for PCB Design (PL-206)

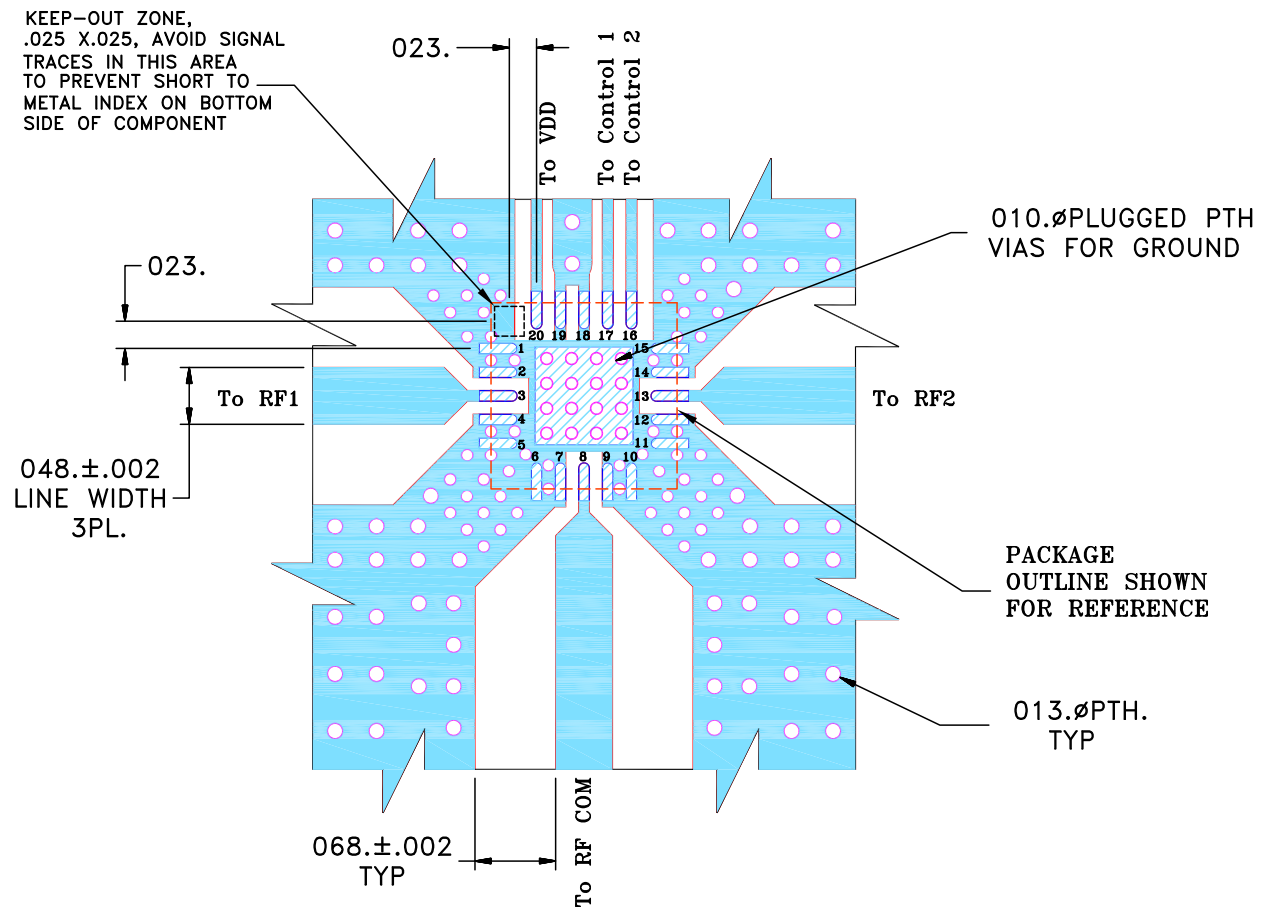

NOTES:

- TRACE WIDTH IS SHOWN FOR FR4 WITH DIELECTRIC THICKNESS. .025"±.002". COPPER: 1/2 OZ. EACH SIDE. FOR OTHER MATERIALS TRACE WIDTH MAY NEED TO BE MODIFIED.
- BOTTOM SIDE OF THE PCB IS CONTINUOUS GROUND PLANE.

- DENOTES PCB COPPER LAYOUT WITH SMOBC (SOLDER MASK OVER BARE COPPER)
- DENOTES COPPER LAND PATTERN FREE OF SOLDERMASK

Recommended layout for PCB design

The amount of vias surrounding the device in the suggested PCB layout are critical for obtaining the specified isolation performance for the device shown in the datasheet.

TB-347 Evaluation Board Schematic Diagram

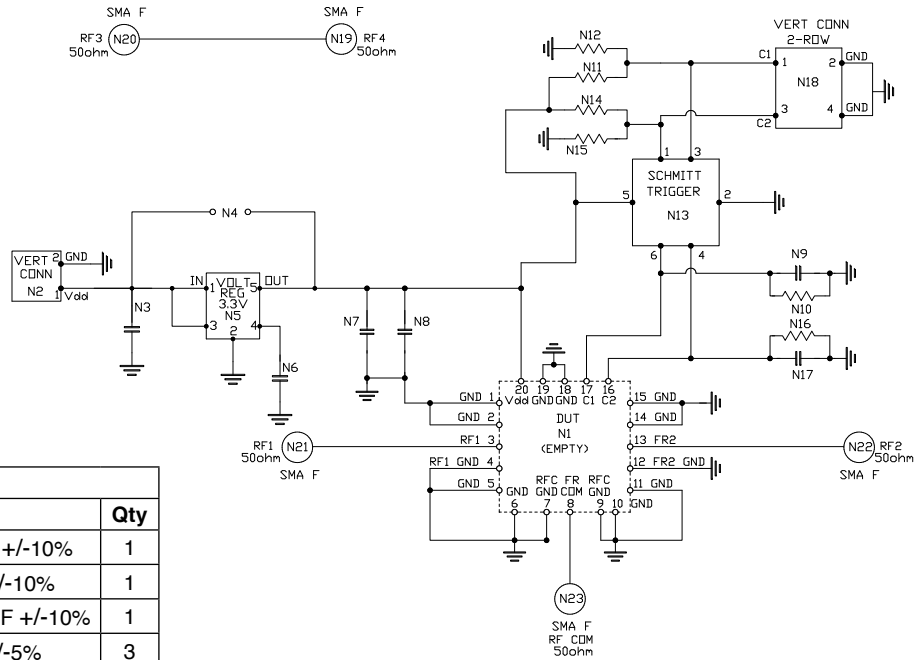

Bill of Materials		
N#	DESCRIPTION	Qty
N3	Capacitor Tantalum 1206 1 μ F +/-10%	1
N6	Capacitor X7R 0402 0.01 μ F +/-10%	1
N7	Capacitor Tantalum 1206 3.3 μ F +/-10%	1
N8, N9, N17	Capacitor 0603 NPO 100pF +/-5%	3
N11, N14	Resistor 0603 1 MOHM +/-1%	2
N12, N15	Resistor 0603 10 MOHM +/-1%	2
N10, N16	Resistor 0603 10 KOHM +/-1%	2
N5	LDO Voltage Regulator 3.3V MAX8878	1
N13	Dual Non-inverted Schmitt Trigger SN74LVC2G17	1
N1	Empty (location for HSWA2-30DR+)	1
N4	Empty	1

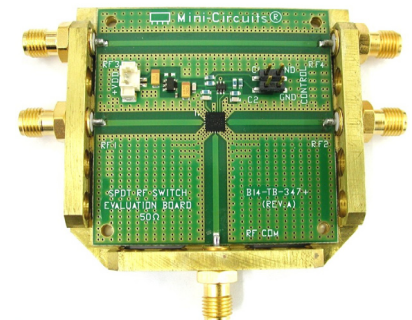

TB-347

How to use evaluation Board TB-347

The Evaluation board TB-347 was designed to evaluate the electrical performance of the HSWA2-30DR+ SPDT switch.

RF3 and RF4 SMA 50 Ω connectors are connected through a 50 Ω transmission line that is used to estimate the evaluation board loss for de-embedding purposes. The transmission lines were designed using a coplanar waveguide with ground plane. For details, please see suggested PCB layout on Page 8. The number of vias surrounding the switch is critical for obtaining the specified isolation.

The TB-347 operates from +2.7V to +6.5V applied to VDD connector. IC1 voltage regulator limits the supply voltage to the switch to +3.3V. IC2 is a Schmitt trigger & buffer which prevents an overload of switch control inputs from high level control signals (up to +5.5V) and prevents from noise and transient spikes during switching process.

The control connector is used for computer control mode or manual operation mode. In manual control mode connect Control 1 and/or Control 2 to ground to set Control 1 and/or Control 2 to logic low, respectively. When jumpers are removed, the digital control input pulled up to VDD for logic high.

For computer control mode the software & cable are supplied. The cable should be connected between computer LPT port and evaluation board control connector.



For detailed performance specs & shopping online see web site

P.O. Box 350166, Brooklyn, New York 11235-0003 (718) 934-4500 Fax (718) 332-4661 The Design Engineers Search Engine Provides ACTUAL Data Instantly at minicircuits.com

IF/RF MICROWAVE COMPONENTS

Notes: 1. Performance and quality attributes and conditions not expressly stated in this specification sheet are intended to be excluded and do not form a part of this specification sheet. 2. Electrical specifications and performance data contained herein are based on Mini-Circuit's applicable established test performance criteria and measurement instructions. 3. The parts covered by this specification sheet are subject to Mini-Circuits standard limited warranty and terms and conditions (collectively, "Standard Terms"); Purchasers of this part are entitled to the rights and benefits contained therein. For a full statement of the Standard Terms and the exclusive rights and remedies thereunder, please visit Mini-Circuits' website at www.minicircuits.com/MCLStore/terms.jsp.

Tape and Reel Packaging Information

Table T&R

TR No.	No. of Devices	Reel Size	Tape Width	Pitch	Unit Orientation
F87	3000	13 inch	12 mm	8 mm	
	multiples of 10, less than full reel of 3K	13 inch			
	multiples of 10, on tape only	not applicable			

Ordering Information

Model No.	Description	Quantity Min. No. of Units	Price \$ Ea.
HSWA2-30DR+	SPDT RF Switch, Single Supply Voltage	10	\$2.95
HSWA2-30DR+TB	HSWA2-30DR+ mounted on test board, test data included	1	\$99.95
TB-347	Test Board Only	1	\$59.95