

# Surface Mount Power Splitter/Combiner

## JSPQW-100+ JSPQW-100

2 Way-90° 50Ω 40 to 100 MHz



### Maximum Ratings

Operating Temperature	-40°C to 85°C
Storage Temperature	-55°C to 100°C
Power Input (as a splitter)	1W max.

Permanent damage may occur if any of these limits are exceeded.

### Pin Connections

SUMPORT	9
PORT 1 (+90°)	2
PORT 2 (0°)	6
GROUND	1,3,4,5,7,8,10,11,12,14
50 OHM TERM EXTERNAL	13

### Outline Drawing

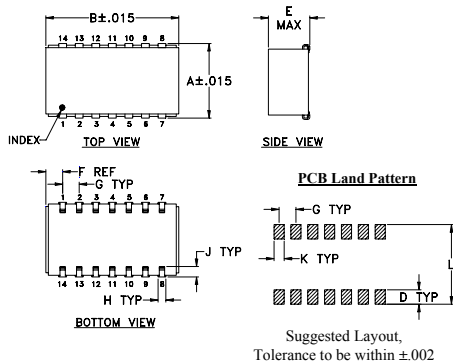

### Outline Dimensions (inch/mm)

A	B	C	D	E	F	G	H	J	K	L	wt
.450	.803	--	.100	.250	.102	.100	.047	.065	.065	.470	grams
11.43	20.40	--	2.54	6.35	2.59	2.54	1.19	1.65	1.65	11.94	3.0

### Demo Board MCL P/N: TB-212 Suggested PCB Layout (PL-098)

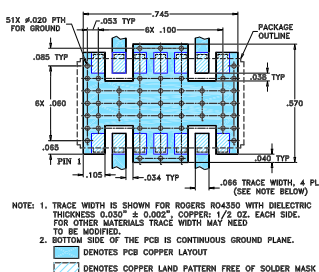

### Features

- low insertion loss, 0.2 dB typ.
- good isolation, 24 dB typ.
- excellent phase unbalance 1 deg. typ.
- good VSWR, 1.20:1 typ.
- aqueous washable

### Applications

- VHF
- instrumentation
- modulators
- image rejection mixers

### Electrical Specifications

FREQ. RANGE (MHz)	ISOLATION (dB)		INSERTION LOSS (dB) Avg. of Coupled Outputs less 3 dB		PHASE UNBALANCE (Degrees)	AMPLITUDE UNBALANCE (dB)
	Typ.	Min.	Typ.	Max.		
f <sub>L</sub> -f <sub>U</sub>					Max.	Max.
40-100	24	18	0.2	0.6	3	1.2

CASE STYLE: BK276  
PRICE: \$14.95 ea. QTY (1-9)

+ RoHS compliant in accordance with EU Directive (2002/95/EC)

The +Suffix identifies RoHS Compliance. See our web site for RoHS Compliance methodologies and qualifications.

### Typical Performance Data

Frequency (MHz)	Insertion Loss (dB)		Amplitude Unbalance (dB)	Isolation (dB)	Phase Unbalance (deg.)	VSWR S	VSWR 1	VSWR 2
	S-1	S-2						
40.00	3.49	2.84	0.65	24.92	89.75	1.09	1.10	1.12
43.00	3.34	2.99	0.35	25.05	89.81	1.09	1.10	1.13
46.00	3.22	3.11	0.12	25.16	89.84	1.09	1.10	1.13
50.50	3.10	3.26	0.16	25.44	89.84	1.09	1.10	1.14
55.00	3.02	3.36	0.34	25.72	90.00	1.09	1.10	1.14
59.50	2.98	3.41	0.43	26.08	90.00	1.09	1.10	1.14
64.00	2.97	3.44	0.47	26.47	90.04	1.08	1.10	1.14
68.50	2.98	3.42	0.45	26.94	90.17	1.08	1.09	1.14
73.00	3.02	3.39	0.37	27.43	90.19	1.07	1.08	1.14
77.50	3.08	3.33	0.25	27.88	90.25	1.07	1.08	1.14
82.00	3.15	3.25	0.10	28.30	90.38	1.07	1.07	1.15
88.00	3.29	3.14	0.15	28.51	90.51	1.08	1.07	1.15
94.00	3.47	3.01	0.47	28.09	90.84	1.10	1.07	1.16
97.00	3.57	2.94	0.64	27.59	90.94	1.12	1.08	1.17
100.00	3.69	2.87	0.83	26.95	91.03	1.13	1.09	1.18

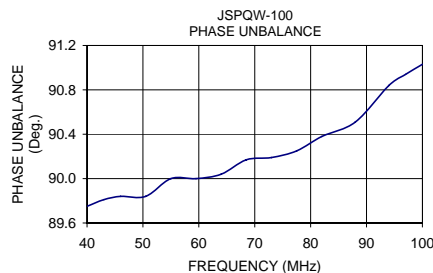
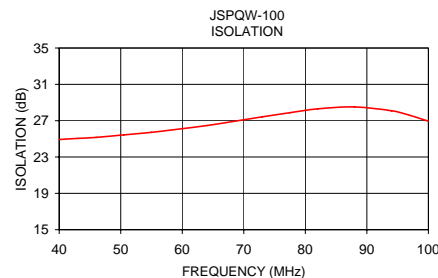
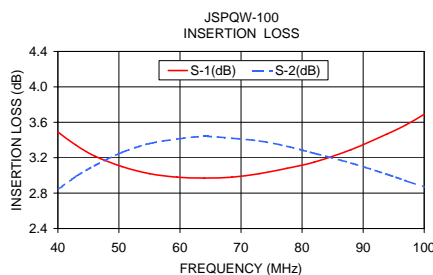

### electrical schematic

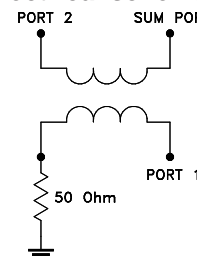

For detailed performance specs & shopping online see web site

**Mini-Circuits®**  
ISO 9001 ISO 14001 AS 9100 CERTIFIED

P.O. Box 350166, Brooklyn, New York 11235-0003 (718) 934-4500 Fax (718) 332-4661 The Design Engineers Search Engine Provides ACTUAL Data Instantly at [minicircuits.com](http://minicircuits.com)

IF/RF MICROWAVE COMPONENTS

Notes: 1. Performance and quality attributes and conditions not expressly stated in this specification sheet are intended to be excluded and do not form a part of this specification sheet. 2. Electrical specifications and performance data contained herein are based on Mini-Circuit's applicable established test performance criteria and measurement instructions. 3. The parts covered by this specification sheet are subject to Mini-Circuits standard limited warranty and terms and conditions (collectively, "Standard Terms"); Purchasers of this part are entitled to the rights and benefits contained therein. For a full statement of the Standard Terms and the exclusive rights and remedies thereunder, please visit Mini-Circuits' website at [www.minicircuits.com/MCLStore/terms.jsp](http://www.minicircuits.com/MCLStore/terms.jsp).

REV. B  
M102713  
JSPQW-100  
LC/TD/CP  
090824