

Surface Mount Voltage Controlled Oscillator

JTOS-50+ JTOS-50

Linear Tuning 25 to 47 MHz

Features

- linear tuning characteristics
- flat tuning sensitivity, 2-2.6 MHz/V typ.
- aqueous washable

Applications

- instrumentation
- VHF/HF
- radio communication



CASE STYLE: BK377
PRICE: \$13.95 ea. QTY (5-49)

+ RoHS compliant in accordance with EU Directive (2002/95/EC)

The +Suffix identifies RoHS Compliance. See our web site for RoHS Compliance methodologies and qualifications.

Electrical Specifications

FREQUENCY (MHz)		POWER OUTPUT (dBm)	TUNING VOLTAGE (V)		PHASE NOISE (dBc/Hz) SSB at offset frequencies: Typ.				PULLING pk-pk @ 12 dB (MHz)	PUSHING (MHz/V)	TUNING SENSITIVITY (MHz/V)	HARMONICS (dBc)		3 dB MODULATION BANDWIDTH (MHz)	DC OPERATING POWER	
Min.	Max.	Typ.	Min.	Max.	1 kHz	10 kHz	100 kHz	1 MHz	Typ.	Typ.	Typ.	Typ.	Max.	Typ.	Vcc (volts)	Current (mA) Max.
25	47	+8.5	1	15	-88	-108	-127	-147	0.06	0.04	2.0-2.6	-19	-12	0.05	12	20

Pin Connections

RF OUT	13
VCC	2
V-TUNE	5
GROUND	1,3,4,6,7,8,9,10,11,12,14

Maximum Ratings

Operating Temperature	-55°C to 85°C
Storage Temperature	-55°C to 100°C
Absolute Max. Supply Voltage (Vcc)	+16V
Absolute Max. Tuning Voltage (Vtune)	+17V

all specifications: 50 ohm system
Permanent damage may occur if any of these limits are exceeded.

Outline Drawing

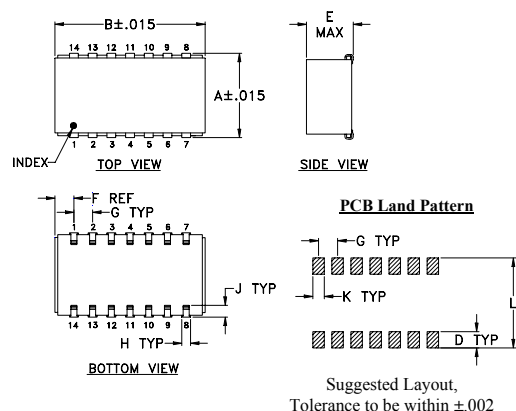

Demo Board MCL PIN: TB-04 Suggested PCB Layout (PL-005)

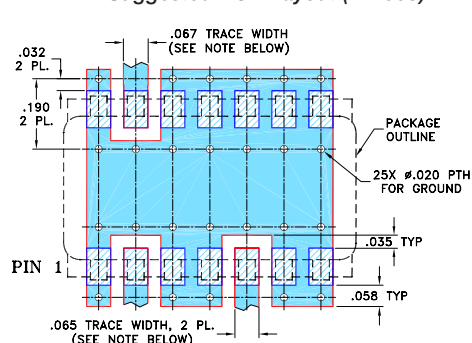

Outline Dimensions (inch/mm)

A	B	C	D	E	F	G	H	J	K	L	wt
.505	.800	--	.100	.250	.100	.100	.047	.065	.065	.525	grams
12.83	20.32	--	2.54	6.35	2.54	2.54	1.19	1.65	1.65	13.34	3.0

Mini-Circuits
ISO 9001 ISO 14001 AS 9100 CERTIFIED

P.O. Box 350166, Brooklyn, New York 11235-0003 (718) 934-4500 Fax (718) 332-4661 The Design Engineers Search Engine Provides ACTUAL Data Instantly at minicircuits.com

IF/RF MICROWAVE COMPONENTS

For detailed performance specs & shopping online see web site

Notes: 1. Performance and quality attributes and conditions not expressly stated in this specification sheet are intended to be excluded and do not form a part of this specification sheet. 2. Electrical specifications and performance data contained herein are based on Mini-Circuit's applicable established test performance criteria and measurement instructions. 3. The parts covered by this specification sheet are subject to Mini-Circuits standard limited warranty and terms and conditions (collectively, "Standard Terms"); Purchasers of this part are entitled to the rights and benefits contained therein. For a full statement of the Standard Terms and the exclusive rights and remedies thereunder, please visit Mini-Circuits' website at www.minicircuits.com/MCLStore/terms.jsp.

REV. B
M102713
ED-3884/1
JTOS-50
MM/TD/CP/AM
091223
Page 1 of 2

Performance Data & Curves

JTOS-50+ JTOS-50

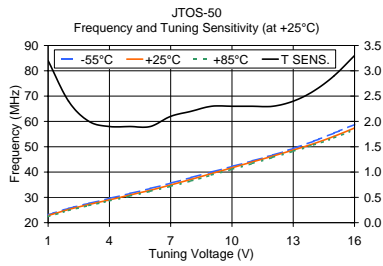

V TUNE	TUNING SENS. (MHz/V)	FREQUENCY (MHz)			POWER OUTPUT (dBm)		
		-55°C	+25°C	+85°C	-55°C	+25°C	+85°C
1.00	3.20	23.10	22.80	22.40	8.68	8.95	8.98
2.00	2.40	25.60	25.20	24.80	9.57	9.79	9.74
3.00	2.00	27.60	27.20	26.80	9.55	9.76	9.80
4.00	1.90	29.60	29.00	28.60	9.44	9.66	9.69
5.00	1.90	31.50	30.90	30.50	9.28	9.51	9.53
6.00	1.90	33.50	32.80	32.40	9.07	9.31	9.33
7.00	2.10	35.60	34.90	34.40	9.24	9.07	9.10
8.00	2.20	37.80	37.10	36.50	9.00	9.20	9.23
9.00	2.30	40.00	39.40	38.80	8.75	8.93	8.93
10.00	2.30	42.20	41.70	41.10	8.50	8.64	8.62
11.00	2.30	44.40	44.00	43.40	8.26	8.37	8.31
12.00	2.30	46.70	46.30	45.80	7.73	7.81	7.73
13.00	2.40	49.30	48.70	48.20	7.41	7.49	7.39
14.00	2.60	52.20	51.20	50.70	7.00	7.14	7.04
15.00	2.90	55.40	54.10	53.50	6.39	6.71	6.64
16.00	3.30	58.80	57.40	56.80	5.93	6.09	6.05

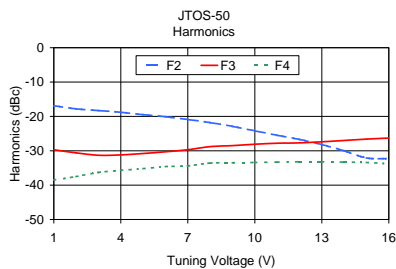
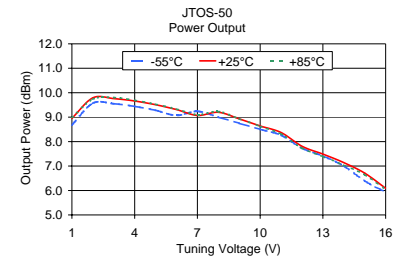

V TUNE	HARMONICS (dBc)			FREQ. PUSHING (MHz/V)
	F2	F3	F4	
1.00	-16.90	-29.70	-38.50	0.03
2.00	-17.80	-30.60	-37.50	0.05
3.00	-18.30	-31.30	-36.30	0.01
4.00	-18.80	-31.20	-35.70	0.00
5.00	-19.50	-30.80	-35.20	0.01
6.00	-20.10	-30.30	-34.60	0.02
7.00	-20.90	-29.70	-34.40	0.03
8.00	-21.80	-28.80	-33.60	0.03
9.00	-22.90	-28.50	-33.50	0.05
10.00	-24.20	-28.10	-33.40	0.07
11.00	-25.50	-27.80	-33.30	0.09
12.00	-26.70	-27.70	-33.20	0.10
13.00	-28.20	-27.40	-33.20	0.09
14.00	-30.00	-27.00	-33.30	0.01
15.00	-32.10	-26.60	-33.40	0.21
16.00	-32.30	-26.30	-33.80	0.47

