

Ceramic

Low Pass Filter

LFCN-5000+

50Ω DC⁽¹⁾ to 5000 MHz



CASE STYLE: FV1206

Maximum Ratings

Operating Temperature	-55°C to 100°C
Storage Temperature	-55°C to 100°C
RF Power Input*	9W max. at 25°C

* Passband rating, derate linearly to 3W at 100°C ambient. Permanent damage may occur if any of these limits are exceeded.

Pin Connections

RF IN	1
RF OUT	3
GROUND	2,4

Outline Drawing

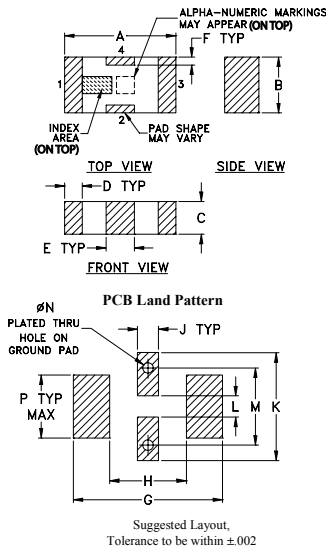

Outline Dimensions (inch/mm)

A	B	C	D	E	F	G
.126	.063	.037	.020	.032	.009	.169
3.20	1.60	0.94	0.51	0.81	0.23	4.29
H	J	K	L	M	N	P
.087	.024	.122	.024	.087	.012	.071
2.21	0.61	3.10	0.61	2.21	0.30	1.80

Demo Board MCL P/N: TB-270 Suggested PCB Layout (PL-137)

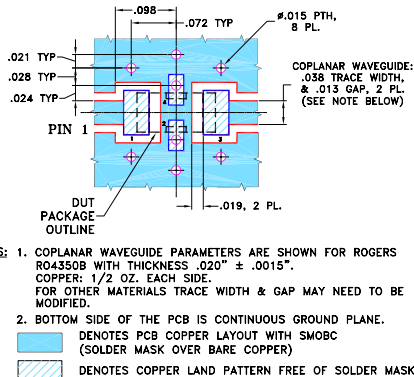

Features

- excellent power handling, 9W
- small size
- 7 sections
- temperature stable
- LTCC construction
- protected by U.S. Patent 6,943,646

Applications

- harmonic rejection
- VHF/UHF transmitters/receivers
- lab use

+RoHS Compliant
The +Suffix identifies RoHS Compliance. See our web site for RoHS Compliance methodologies and qualifications

Available Tape and Reel at no extra cost

Reel Size	Devices/Reel
7"	20, 50, 100, 200, 500, 1000, 3000

Electrical Specifications^(1,2) at 25°C

Parameter	F#	Frequency (MHz)	Min.	Typ.	Max.	Unit	
Pass Band	Insertion Loss	DC-F1	DC-5000	—	—	1.0	dB
	Freq. Cut-Off	F2	5580	—	3.0	—	dB
	VSWR	DC-F1	DC-5000	—	1.2	—	:1
Stop Band	Rejection Loss	F3	6850	20	—	—	dB
		F4-F5	7050	—	30	—	dB
		F6	18000	—	20	—	dB
VSWR	F3-F6	6850-18000	—	20	—	:1	

(1) In Application where DC voltage is present at either input or output ports, coupling capacitors are required.
(2) Measured on Mini-Circuits Characterization Test Board TB-270.

Typical Frequency Response

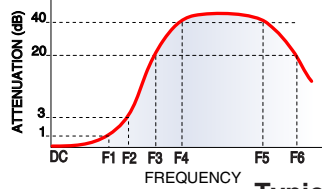

Electrical Schematic

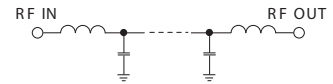

Typical Performance Data at 25°C

Frequency (MHz)	Insertion Loss (dB)	VSWR (:1)
50.00	0.01	1.01
500.00	0.10	1.03
1000.00	0.14	1.04
2000.00	0.26	1.07
3000.00	0.31	1.15
4000.00	0.51	1.25
5000.00	0.68	1.05
5800.00	4.91	5.30
6830.00	40.67	22.58
8000.00	28.12	31.03
11000.00	32.43	157.93
13000.00	25.15	1.71
15000.00	24.88	29.46
18000.00	18.17	26.33
20000.00	23.63	8.43

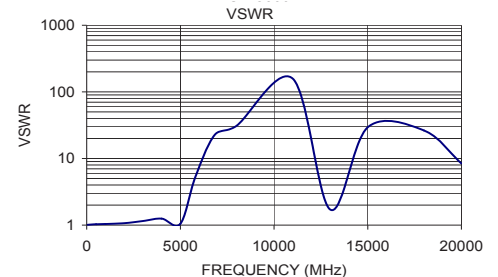

Notes

- A. Performance and quality attributes and conditions not expressly stated in this specification document are intended to be excluded and do not form a part of this specification document.
- B. Electrical specifications and performance data contained in this specification document are based on Mini-Circuit's applicable established test performance criteria and measurement instructions.
- C. The parts covered by this specification document are subject to Mini-Circuits standard limited warranty and terms and conditions (collectively, "Standard Terms"); Purchasers of this part are entitled to the rights and benefits contained therein. For a full statement of the Standard Terms and the exclusive rights and remedies thereunder, please visit Mini-Circuits' website at www.minicircuits.com/MCLStore/terms.jsp

