

Fast Switching SPDT RF Switch

50Ω 0.3 - 4500 MHz

Absorptive RF Switch with internal driver
Single Supply Voltage, +3V to +5V

Product Features

- High Isolation, 52 dB at 1 GHz
- Low insertion loss, 0.8 dB typ. at 1 GHz
- Low supply current consumption, 50 μA typ.
- Fast Rise/Fall time, 16 ns typ.

Typical Applications

- Defense
- Communication Infrastructure
- Test and Measurements



M3SWA-2-50DRA+

CASE STYLE: DL805

+RoHS Compliant

The +Suffix identifies RoHS Compliance. See our web site for RoHS Compliance methodologies and qualifications

General Description

M3SWA-2-50DRA+ is a high isolation fast switching absorptive SPDT switch with integral CMOS driver, operates with single positive supply voltage while consuming, 50 μA typical. It has been designed for wide-band operation. It is packaged in a tiny 3.25mm x 3.25mm, 8-lead package passes 250V for ESD (HBM).

Simplified Schematic and Pad Description

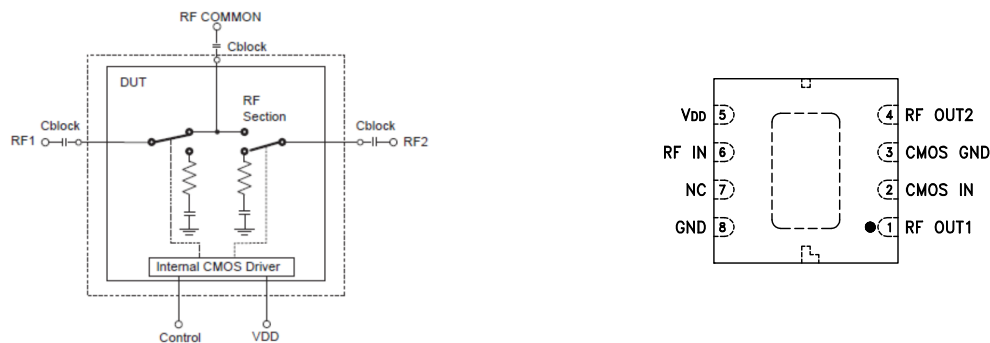

Function	Pad Number	Description
RF IN	6	RF common/ SUM port, requires external DC block
RF OUT1	1	RF out #1/In port #1, requires external DC block
RF OUT2	4	RF out #1/In port #2, requires external DC block
CONTROL	2	CMOS Control IN
VDD	5	Supply voltage
NC	7	No Connection
CMOS GND	3	CMOS ground
GND	8 &, paddle	RF ground

RF Electrical Specifications¹, T_{AMB}=25°C, 50Ω, V_{DD}= +5V

Parameter	Condition (MHz)	Min.	Typ.	Max.	Units
Frequency range		10		4500	MHz
Insertion loss ^{2,3}	10		0.6	1.0	dB
	100		0.7	1.0	
	1000		0.8	1.2	
	2000		1.0	1.4	
	4500		1.2	1.9	
Isolation between Common port and RF1/RF2 Ports	10		74.0		dB
	100		59.3		
	1000		61.5		
	2000		50.8		
	4500		39.5		
Isolation between RF1 and RF2 ports	10		74.3		dB
	100		61.0		
	1000		51.8		
	2000		46.5		
	4500		37.4		
Return loss (ON STATE)	10		24.3		dB
	100		24.1		
	1000		20.8		
	2000		16.7		
	4500		17.0		
Return loss (OFF STATE)	500		12.9		dB
	1000		20.1		
	2000		28.6		
	4500		12.8		
	2000-4500		27		
Input 0.2 dB Compression	500-1000		30		dBm
	1000-2000		30		
	2000-4500		27		

DC Electrical Specifications

Parameter	Min.	Typ.	Max.	Units
Supply voltage, V _{DD}	3.0		5.0	V
Supply current		50	200	μA
Control voltage Low	0		0.5	V
Control voltage High	0.7 V _{DD}		V _{DD}	V
Control current		0.2	10	μA

Notes:

1. Tested on Mini-Circuits' test board TB-159+, using Agilent's N5230A network analyzer (see Characterization test circuit, Fig.1).
2. Insertion loss values are de-embedded from test board loss.
3. Needs external blocking capacitors on all RF ports. (Suggested value=47pF)

Switching Specifications

Parameter	Condition	Min.	Typ.	Max.	Units
Switching time 50% Control to 90%/10% RF	RF Pin=0dBm RF Freq.=500 MHz Control Freq.=500 KHz Control High=3.7V Control Low=0V		29		nS
Video Leakage	RF Pin=0dBm RF Freq.=500 MHz Control Freq.=500 KHz Control High=3.7V Control Low=0V		24.8		mV
Rise/Fall Time 10 to 90% or 90 to 10%	RF Pin=0dBm RF Freq.=500 MHz Control Freq.=500 KHz Control High=3.7V Control Low=0V		16		nS

Absolute Maximum Ratings⁵

Parameter	Ratings
Operating temperature	-55°C to +100°C
Storage temperature	-55°C to +100°C
V _{DD} , Supply voltage (V)	2.7 Min., 5.5 Max.
Voltage control (V)	-0.2V Min., V _{DD} Max
RF Input power (dBm)	+30 dBm

5. Operation of this device above any of these conditions may cause permanent damage.

Truth Table (State of control voltage selects the desired switch state)

State of Control voltage	RF common to	
	RF1	RF2
Hi	OFF	ON
Low	ON	OFF

ON- low insertion loss state OFF- Isolation State

Characterization Test Circuit

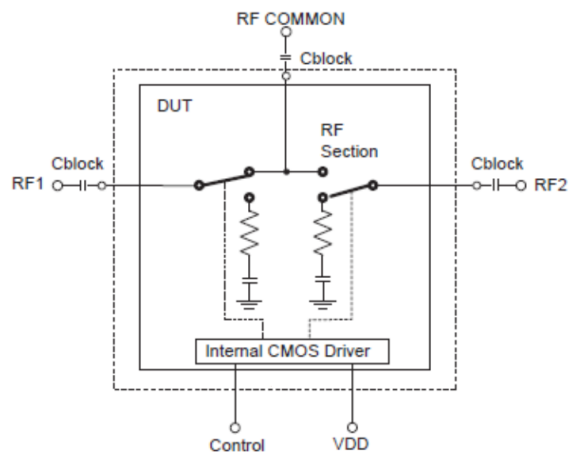
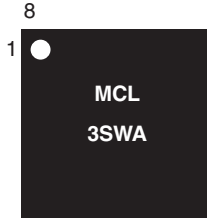

Figure 1. Block Diagram of test Circuit used for characterization (DUT soldered on Mini-Circuit's TB-159A+)

Frequency (MHz)	Cblock (Suggested Value)
0.3-500	0.1 μF
500-4500	47 pF

Product Marking

Marking may contain other features or characters for internal lot control

Additional Detailed Technical Information

additional information is available on our dash board.

Performance Data	Data Table
	Swept Graphs
Case Style	DL805 <i>Plastic package, exposed paddle</i>
Tape & Reel Standard quantities available on reel	F58 <i>7" reels with 1000 devices</i> <i>13" reels with 2000, 4000 devices</i>
Suggested Layout for PCB Design	PL-120A
Evaluation Board	TB-159A+
Environmental Ratings	ENV16

ESD Rating

Human Body Model (HBM): Class 1A (250 to 500V) in accordance with ESD STM5.1-2001

Additional Notes

- A. Performance and quality attributes and conditions not expressly stated in this specification document are intended to be excluded and do not form a part of this specification document.
- B. Electrical specifications and performance data contained in this specification document are based on Mini-Circuit's applicable established test performance criteria and measurement instructions.
- C. The parts covered by this specification document are subject to Mini-Circuits standard limited warranty and terms and conditions (collectively, "Standard Terms"); Purchasers of this part are entitled to the rights and benefits contained therein. For a full statement of the Standard Terms and the exclusive rights and remedies thereunder, please visit Mini-Circuits' website at www.minicircuits.com/MCLStore/terms.jsp