

Surface Mount

Dual Matched MMIC Amplifier

DC-1 GHz

Product Features

- Two matched 50-ohm amplifiers in one package
- InGaP HBT IF and RF amplifier
- Frequency range DC to 1 GHz
- High gain, 25 dB typ. at 0.1 GHz
- Up to +19 dBm typ. output power at 0.1 GHz
- High IP3, +36 dBm at 0.1 GHz
- Low noise figure, 2.7 dB typ.
- Low thermal resistance
- Transient protected
- Useable as balanced and push pull amplifier
- Protected by US Patent 6,943,629

Typical Applications

- Cellular
- CATV
- UHF/VHF communications
- Receivers & transmitters

General Description

MERA-7433+ is a dual matched wideband amplifier offering high dynamic range. It has repeatable performance from lot to lot. It is enclosed in a 3.25 x 3.25 mm MCLP plastic package. MERA-7433+ uses Darlington configuration and is fabricated using InGaP HBT technology. Expected MTBF at 85°C case temperature is 300 years for the entire device (A1 and A2).



MERA-7433+

CASE STYLE: DL805
PRICE: \$4.70 ea. QTY. (25)

+ RoHS compliant in accordance with EU Directive (2002/95/EC)

The +Suffix has been added in order to identify RoHS Compliance. See our web site for RoHS Compliance methodologies and qualifications.

simplified schematic (each of A1, A2) and pin description

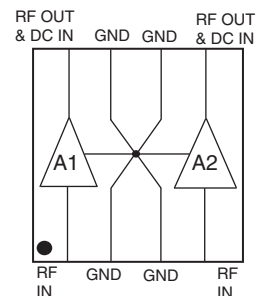
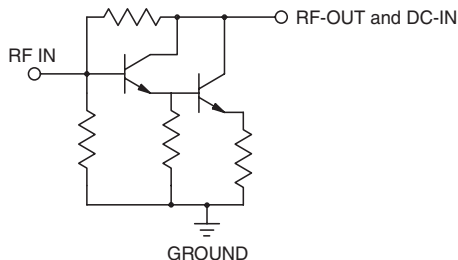

Function	Pin Number	Description
RF IN, A1	1	RF input pin. This pin requires the use of an external DC blocking capacitor chosen for the frequency of operation.
RF-OUT and DC-IN, A1	8	RF output and bias pin. DC voltage is present on this pin; therefore a DC blocking capacitor is necessary for proper operation. An RF choke is needed to feed DC bias without loss of RF signal due to the bias connection, as shown in "Recommended Application Circuit".
RF IN, A2	4	RF input pin. This pin requires the use of an external DC blocking capacitor chosen for the frequency of operation.
RF-OUT and DC-IN, A2	5	RF output and bias pin. DC voltage is present on this pin; therefore a DC blocking capacitor is necessary for proper operation. An RF choke is needed to feed DC bias without loss of RF signal due to the bias connection, as shown in "Recommended Application Circuit".
GND	2,3,6,7 & paddle	Connections to ground. Use via holes as shown in "Suggested Layout for PCB Design" to reduce ground path inductance for best performance.

Mini-Circuits®
ISO 9001 ISO 14001 AS 9100 CERTIFIED

P.O. Box 350166, Brooklyn, New York 11235-0003 (718) 934-4500 Fax (718) 332-4661 The Design Engineers Search Engine Provides ACTUAL Data Instantly at minicircuits.com

IF/RF MICROWAVE COMPONENTS

For detailed performance specs & shopping online see web site

Notes: 1. Performance and quality attributes and conditions not expressly stated in this specification sheet are intended to be excluded and do not form a part of this specification sheet. 2. Electrical specifications and performance data contained herein are based on Mini-Circuit's applicable established test performance criteria and measurement instructions. 3. The parts covered by this specification sheet are subject to Mini-Circuits standard limited warranty and terms and conditions (collectively, "Standard Terms"); Purchasers of this part are entitled to the rights and benefits contained therein. For a full statement of the Standard Terms and the exclusive rights and remedies thereunder, please visit Mini-Circuits' website at www.minicircuits.com/MCLStore/terms.jsp.

REV. E
M126530
MERA-7433+
081215
Page 1 of 4

Electrical Specifications at 25°C and 80mA, unless noted
(Specifications (other than Matching) are for each of the two matched amplifiers)

Parameter		Min.	Typ.	Max.	Units
Frequency Range*		DC		1	GHz
Gain	f=0.1 GHz		25		dB
	f=1 GHz	20	22.4		
	f=2 GHz		19		
	f=3 GHz		16.2		
	f=4 GHz		13.4		
Input Return Loss	f=DC to 1 GHz		19		dB
Output Return Loss	f=DC to 1 GHz		11		dB
Output Power @ 1 dB compression	f=0.1 GHz	18	19		dBm
	f=1 GHz		18.3		
	f=2 GHz		14.8		
Output IP3	f=0.1 GHz		36		dBm
	f=0.5 GHz		35		
	f=1 GHz		32		
Noise Figure	f=DC to 1 GHz		2.7		dB
Matching between A1, A2 ²	Amplitude Unbalance	f=DC to 1 GHz	0.15	0.3	dB
		f=1 to 4 GHz	0.3		
	Phase Unbalance	f=DC to 1 GHz		0.5	deg.
		f=1 to 4 GHz		1.0	
Recommended Device Operating Current			80		mA
Device Operating Voltage		4.3	4.8	5.3	V
Device Voltage Variation vs. Temperature at 80 mA			-3.1		mV/°C
Device Voltage Variation vs. Current at 25°C			2.8		mV/mA
Thermal Resistance, junction-to-case ¹ , A1 or A2			120		°C/W

*Guaranteed specification DC-1 GHz. Low frequency cut off determined by external coupling capacitors.

Absolute Maximum Ratings

Parameter	Ratings
Operating Temperature	-45°C to 85°C
Storage Temperature	-55°C to 100°C
Operating Current	130mA
Power Dissipation	700mW
Input Power	10dBm

Note: Permanent damage may occur if any of these limits are exceeded.
 These ratings are not intended for continuous normal operation.

¹Case is defined as ground paddle. See application note AN-60-032 for adequate heat sinking of paddle.

²For test method, see application note AN-60-032.

Product Marking

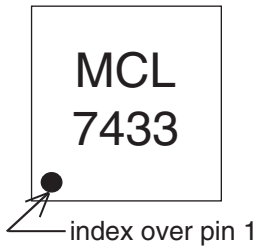

Additional Detailed Technical Information

Additional information is available on our web site. To access this information enter the model number on our web site home page.

Performance data, graphs, s-parameter data set (.zip file)

Case Style: DL805

Plastic package, exposed paddle, lead finish: tin/silver/nickel

Tape & Reel: F58

Suggested Layout for PCB Design: PL-165

Evaluation Board: TB-294

Environmental Ratings: ENV08T2

Recommended Application Circuit

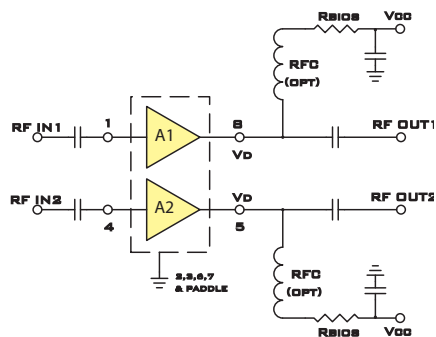

For detailed performance specs & shopping online see web site

P.O. Box 350166, Brooklyn, New York 11235-0003 (718) 934-4500 Fax (718) 332-4661 *The Design Engineers Search Engine* Provides ACTUAL Data Instantly at minicircuits.com

Notes: 1. Performance and quality attributes and conditions not expressly stated in this specification sheet are intended to be excluded and do not form a part of this specification sheet. 2. Electrical specifications and performance data contained herein are based on Mini-Circuit's applicable established test performance criteria and measurement instructions. 3. The parts covered by this specification sheet are subject to Mini-Circuits standard limited warranty and terms and conditions (collectively, "Standard Terms"); Purchasers of this part are entitled to the rights and benefits contained therein. For a full statement of the Standard Terms and the exclusive rights and remedies thereunder, please visit Mini-Circuits' website at www.minicircuits.com/MCLStore/terms.jsp.

ESD Rating

Human Body Model (HBM): Class 1C (1000 v to < 2000 v) in accordance with ANSI/ESD STM 5.1 - 2001

Machine Model (MM): Class M2 (100 v to < 200 v) in accordance with ESD STM 5.2-1999

MSL Rating

Moisture Sensitivity: MSL1 in accordance with IPC/JEDECJ-STD-020C

No.	Test Required	Condition	Standard	Quantity
1	Visual Inspection	Low Power Microscope Magnification 40x	MIP-IN-0003 (MCT spec)	114 units
2	Electrical Test	Room Temperature	SCD (MCL spec)	114 units
3	SAM Analysis	Less than 10% growth in term of delamination	J-Std-020C (Jedec Standard)	114 units
4	Moisture Sensitivity Level 1	Bake at 125°C for 24 hours Soak at 85°C/85%RH for 168 hours Reflow 3 cycles at 250°C peak	J-Std-020C (Jedec Standard)	114 units

MSL Test Flow Chart

