

# Coaxial Frequency Mixer

## ZFM-2000+

### Level 7 (LO Power +7 dBm) 100 to 2000 MHz



SMA version shown  
CASE STYLE: K18

#### Maximum Ratings

Operating Temperature	-55°C to 100°C
Storage Temperature	-55°C to 100°C
RF Power	50mW
IF Current	40mA

Permanent damage may occur if any of these limits are exceeded.

#### Coaxial Connections

LO	1
RF	2
IF	3

#### Features

- low conversion loss, 7.49 dB typ.
- good L-R isolation, 37 dB typ, L-I, 30 dB typ.
- wideband, 100 to 2000 MHz
- rugged shielded case

#### Applications

- VHF/UHF
- cellular
- GPS
- instrumentation

Connectors	Model	Price	Qty.
SMA	ZFM-2000+	\$71.95 ea.	(1-9)
BRACKET (OPTION "B")		\$2.50	(1+)

**+ RoHS compliant in accordance with EU Directive (2002/95/EC)**

The +Suffix has been added in order to identify RoHS Compliance. See our web site for RoHS Compliance methodologies and qualifications.

#### Outline Drawing

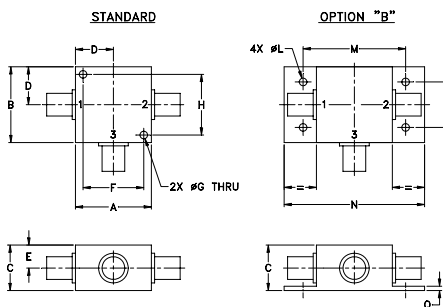

#### Outline Dimensions (inch/mm)

A	B	C	D	E	F	G	H
1.25	1.25	.75	.63	.38	1.00	.125	1.000
31.75	31.75	19.05	16.00	9.65	25.40	3.18	25.40
J	K	L	M	N	P	Q	wt
--	--	.125	1.688	2.18	.75	.07	grams
--	--	3.18	42.88	55.37	19.05	1.78	70.0

#### Electrical Specifications

FREQUENCY (MHz)		CONVERSION LOSS (dB)				LO-RF ISOLATION (dB)		LO-IF ISOLATION (dB)	
LO/RF	IF	Mid-Band			Total Range Max.	Typ.	Min.	Typ.	Min.
$f_L-f_U$		$\bar{X}$	$\sigma$	Max.					
100-2000	DC-600	7.49	0.20	9.5	9.5	37	20	30	20

1 dB COMP.: +1 dBm typ.

#### Typical Performance Data

Frequency (MHz)		Conversion Loss (dB)	Isolation L-R (dB)	Isolation L-I (dB)	VSWR RF Port (:1)	VSWR LO Port (:1)
RF	LO	LO +7dBm	LO +7dBm	LO +7dBm	LO +7dBm	LO +7dBm
100.00	130.00	7.88	63.45	46.41	5.22	2.43
200.00	230.00	7.16	60.41	40.82	5.25	2.36
267.65	237.65	7.37	58.33	38.59	5.06	2.39
435.29	405.29	7.73	51.41	34.21	4.59	2.43
500.00	470.00	7.83	52.88	33.31	4.34	2.42
602.94	572.94	7.78	52.63	32.54	4.17	2.42
714.71	684.71	7.91	54.29	30.27	3.55	2.34
770.59	740.59	8.02	54.64	30.10	3.13	2.34
938.24	908.24	7.66	60.17	29.50	2.55	2.24
994.12	964.12	7.51	59.11	29.33	2.52	2.22
1000.00	970.00	7.53	59.12	29.29	2.46	2.17
1161.76	1131.77	7.40	49.13	27.43	2.35	2.08
1273.53	1243.53	7.46	43.70	26.26	2.23	1.83
1385.29	1355.29	7.55	36.51	24.00	2.11	1.44
1441.18	1411.18	7.71	34.04	26.34	1.99	1.29
1552.94	1522.94	7.73	36.54	38.03	2.03	1.16
1720.59	1690.59	7.45	42.35	34.48	2.12	1.12
1888.24	1858.24	7.47	44.03	33.01	2.23	1.41
1944.12	1914.12	7.51	43.94	32.64	2.28	1.68
2000.00	1970.00	7.54	43.18	32.15	2.26	1.79

#### Electrical Schematic

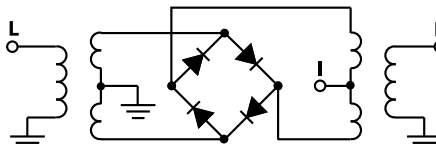

**Mini-Circuits**  
ISO 9001 ISO 14001 AS 9100 CERTIFIED

For detailed performance specs & shopping online see web site

P.O. Box 350166, Brooklyn, New York 11235-0003 (718) 934-4500 Fax (718) 332-4661 The Design Engineers Search Engine Provides ACTUAL Data Instantly at [minicircuits.com](http://minicircuits.com)

IF/RF MICROWAVE COMPONENTS

Notes: 1. Performance and quality attributes and conditions not expressly stated in this specification sheet are intended to be excluded and do not form a part of this specification sheet. 2. Electrical specifications and performance data contained herein are based on Mini-Circuits' applicable established test performance criteria and measurement instructions. 3. The parts covered by this specification sheet are subject to Mini-Circuits standard limited warranty and terms and conditions (collectively, "Standard Terms"); Purchasers of this part are entitled to the rights and benefits contained therein. For a full statement of the Standard Terms and the exclusive rights and remedies thereunder, please visit Mini-Circuits' website at [www.minicircuits.com/MCLStore/terms.jsp](http://www.minicircuits.com/MCLStore/terms.jsp).

REV. B  
M113397  
ZFM-2000+  
DJ/TD/CP  
080508  
Page 1 of 2

